

Mini-/ Micro-Werkzeuge *Mini-/ Micro- Tools*

5



Drehen
Turning

Fräswerkzeuge
Milling Tools

HDS-/VHM- Fräser
HDS-/ Solid Carbide
Endmills



Stech- und
Abstechwerkzeuge
Grooving and
Parting off Tools

Mini/ Micro
Schneidwerkzeuge
Mini/ Micro Tools



Gewinde-
werkzeuge
Threading Tools

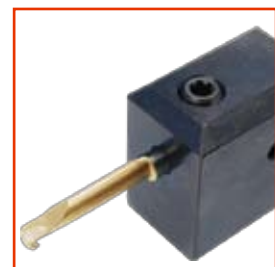

Wendepplattenbohrer
VHM-Bohrer
Indexable Drills
Solid Carbide Drills

... Qualität schafft Vertrauen

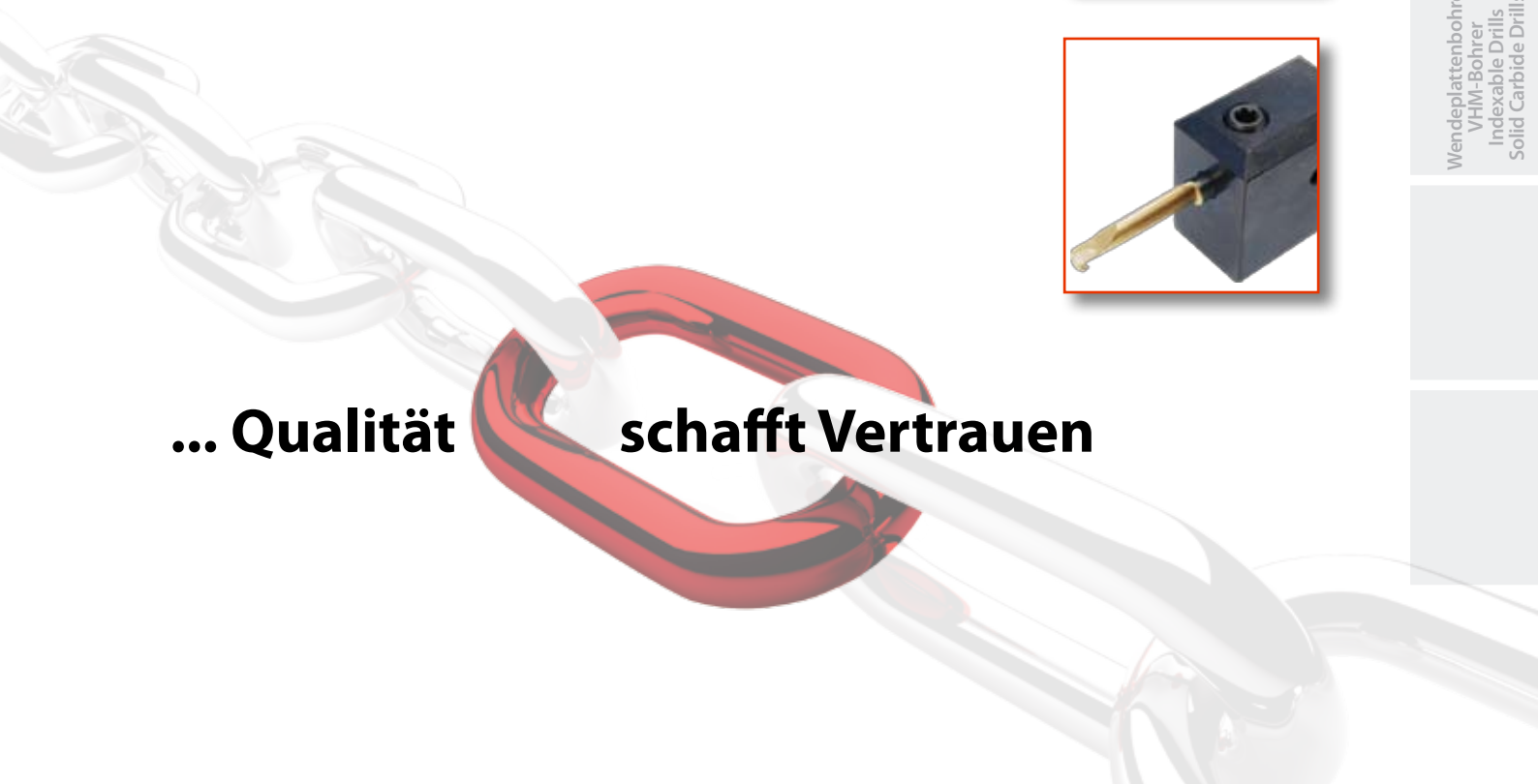

Drehen
Turning

Fräswerkzeuge
Milling Tools

HDS-/VHM-Fräser
HDS-/ Solid Carbide
Endmills

Stech- und
Abstechwerkzeuge
Grooving and
Parting off Tools

Mini/Micro
Schneidwerkzeuge
Mini/ Micro Tools

Gewinde-
werkzeuge
Threading Tools



Wendeplattenbohrer
VHM-Bohrer
Indexable Drills
Solid Carbide Drills

	Seite Page
Mini - Hartmetall-Klemmhalter <i>Mini - Carbide Toolholders</i> 	5.04
Mini-Schneideinsätze <i>Mini Inserts</i>	
Stechdrehen und NC-Feindrehen / <i>Grooving and NC Profiling</i> D_{min} 8 / 10 / 11 / 14 / 16 mm 	5.05
Stechdrehen / Vollradius / <i>Grooving / Full Radius</i> 	5.09
Ausdrehen / Kopieren / <i>Boring / Copying</i> 	5.10
Ausdrehen / Freistechen 40° / <i>Boring / Profiling 40°</i> 	5.10
Rückwärtsdrehen / <i>Boring by Backward Motion</i> 	5.11
Fasen / Ausdrehen / <i>Chamfering / Boring</i> 	5.12
Vorstechen / Fasen / <i>Pregrooving / Chamfering</i> 	5.12
Gewindedrehen, metrisch 60°, Teilprofil / <i>Threading, Metric 60°, Partial Profile</i> 	5.13
Gewindedrehen, metrisch 60°, Vollprofil / <i>Threading, Metric 60°, Full Profile</i> 	5.14
Gewindedrehen, BSW 55°, Vollprofil / <i>Threading, BSW 55°, Full Profile</i> 	5.15
Gewindedrehen, Trapez DIN 103, ACME / <i>Threading, Trapez DIN 103, ACME</i> 	5.15
Axialstechen / <i>Face Grooving</i> 	5.16
Axialstechen, Kontra-Version / <i>Face Grooving, Contra Version</i> 	5.16
Schnittdaten - Empfehlungen / Schneidstoffe <i>Cutting Data Recommendations / Carbide Grades</i>	5.17

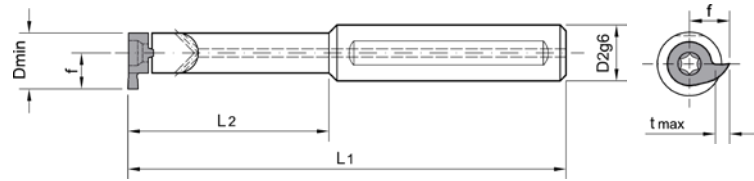
D 08-HM/ST D 10-HM/ST D 11-HM/ST D 14-HM/ST D 16-HM/ST



Hartmetall-Klemmhalter mit innerer Kühlmittelzufuhr
Carbide-Toolholder with Through Coolant

Bezeichnung Part Number	Lager Stock	Maße [mm] Dimensions						Ersatzteile Spare Parts	
		D _{2g6}	L ₁	L ₂	ØD _{min}	t _{max}	f		
D 08. 0012. 21 HM	○		80	21				32.40.101	56.33.612
D 08. 0012. 30 HM	○		90	30					
D 08. 0012. 42 HM	○	12	100	42	8	1.0	4.8		
D 08. 0012. 50 HM	○		110	50					
D 08. 0016. 12 ST	○	16	80	12					
D 10. 0012. 32 HM	○		100	32				32.40.105	75.20.617
D 10. 0012. 48 HM	○	12	115	48	10	3.4	5.8/7.4		
D 10. 0012. 64 HM	○		130	64					
D 10. 0016. 16 ST	○	16	97	16					
D 11. 0012. 29 HM	○		95	29				32.40.102	75.20.618
D 11. 0012. 42 HM	○	12	110	42					
D 11. 0012. 56 HM	○		120	56	11	2.3	6.7		
D 11. 0012. 64 HM	○		130	64					
D 11. 0016. 16 ST	○	16	97	16					
D 14. 0012. 34 HM	○		100	34				32.40.103	56.33.613
D 14. 0012. 45 HM	○	12	110	45					
D 14. 0012. 64 HM	○		130	64					
D 14. 0016. 34 HM	○		100	34					
D 14. 0016. 45 HM	○		110	45	14	4.0	9.0/11.5		
D 14. 0016. 64 HM	○	16	130	64					
D 14. 0016. 75 HM	○		145	75					
D 14. 0016. 20 ST	○		100	20					
D 16. 0012. 40 HM	○		130	40				32.40.104	56.33.614
D 16. 0012. 56 HM	○	12	130	56					
D 16. 0012. 80 HM	○		150	80					
D 16. 0016. 40 HM	○		130	40	16	4.3	10.2		
D 16. 0016. 56 HM	○	16	130	56					
D 16. 0016. 80 HM	○		150	80					
D 16. 0016. 22 ST	○		100	22					

Klemmhalter sind für rechte und linke Schneideinsätze verwendbar.

Toolholders can be used for RH and LH inserts.

HM Hartmetall Carbide

ST Stahl Steel

Stechdrehen und NC-Feindrehen

Grooving and NC-Profiling

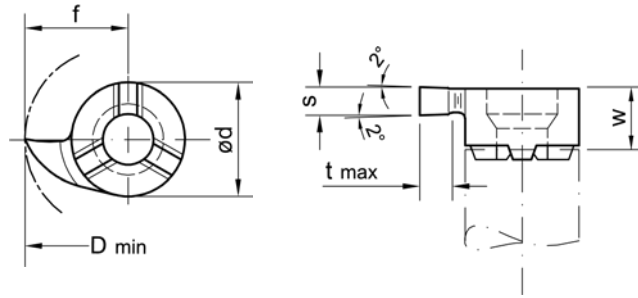

Bezeichnung Part Number	Lager Stock				Maße [mm] Dimensions							
	GK 1120		GK 5120		S _{+0,03}	Nuttennbreite Circlip	ØD _{min}	t _{max}	f	r	ød	w
	R	L	R	L								
D 08. 0070. 00 R/L			○	○	0.73	0.7						
D 08. 0080. 00 R/L			○	○	0.83	0.8						3.6
D 08. 0090. 00 R/L			○	○	0.93	0.9						
D 08. 0100. 00 R/L			○	○	1.00	-						
D 08. 0110. 00 R/L			○	○	1.20	1.1						
D 08. 0130. 00 R/L			○	○	1.40	1.3	8.0	1.0	4.8	-	6.0	
D 08. 0150. 00 R/L			○	○	1.50	-						3.3
D 08. 0160. 00 R/L			○	○	1.70	1.6						
D 08. 0200. 00 R/L			○	○	2.00	-						
D 08. 0150. 02 R/L			○	○	1.50	-				0.2		
D 08. 0200. 02 R/L			○	○	2.00	-						
D 10. 0070. 00.10 R/L			○	○	0.73	0.7		1.2				
D 10. 0080. 00.10 R/L			○	○	0.83	0.8		1.3				
D 10. 0090. 00.10 R/L			○	○	0.93	0.9		1.5				
D 10. 0100. 00.10 R/L			○	○	1.00	-						
D 10. 0110. 00.10 R/L			○	○	1.20	1.1						
D 10. 0130. 00.10 R/L			○	○	1.40	1.3	10.0		5.8	-	7.0	3.9
D 10. 0150. 00.10 R/L			○	○	1.50	-						
D 10. 0160. 00.10 R/L			○	○	1.70			1.8				
D 10. 0200. 00.10 R/L			○	○	2.00							
D 10. 0250. 00.10 R/L			○	○	2.50	1.6						
D 10. 0300. 00.10 R/L			○	○	3.00							

Ausführung R oder L angeben / state R or L version
 R = rechts, wie gezeichnet R = RH version shown
 L = links, spiegelbildlich L = LH version, mirror image

Drehen
Turning

Fräswerkzeuge
Milling Tools

HDS-/VHM-Fräser
HDS-/Solid Carbide
Endmills

Stech- und
Abstechwerkzeuge
Grooving and
Parting off Tools

Mini/Micro
Schneidwerkzeuge
Mini/Micro Tools

Gewinde-
werkzeuge
Threading Tools

Wendepplattenbohrer
VHM-Bohrer
Indexable Drills
Solid Carbide Drills

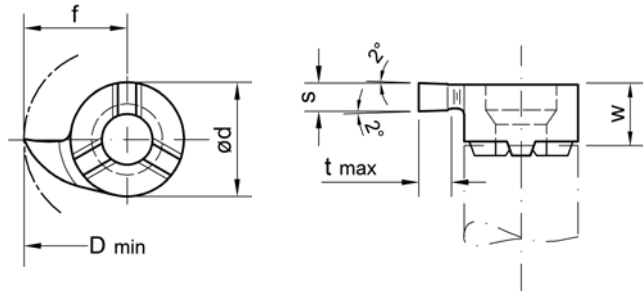

Bezeichnung Part Number	Lager Stück				Maße [mm] Dimensions							
	GK 1120		GK 5120		S _{+0,03}	Nuttennbreite Circlip	ØD _{min}	t _{max}	f	r	ød	w
	R	L	R	L								
D 10. 0100. 00. 11 R/L			○	○	1.00							
D 10. 0150. 00. 11 R/L			○	○	1.50							
D 10. 0200. 00. 11 R/L			○	○	2.00		11.0	2.8	6.8			
D 10. 0250. 00. 11 R/L			○	○	2.50							
D 10. 0300. 00. 11 R/L			○	○	3.00							
D 10. 0100. 00. 12 R/L			○	○	1.00							
D 10. 0150. 00. 12 R/L			○	○	1.50		12.0	3.4	7.4		7.0	3.9
D 10. 0200. 00. 12 R/L			○	○	2.00							
D 10. 0150. 02. 11 R/L			○	○	1.50							
D 10. 0200. 02. 11 R/L			○	○	2.00		11.0	2.8	6.8			
D 10. 0150. 02. 12 R/L			○	○	1.50							
D 10. 0200. 02. 12 R/L			○	○	2.00		12.0	3.4	7.4	0.2		
D 10. 0150. 02 R/L			○	○	1.50							
D 10. 0200. 02 R/L			○	○	2.00		10.0	1.8	5.8			
D 11. 0070. 00 R/L			○	○	0.73	0.7		1.2				
D 11. 0080. 00 R/L			○	○	0.83	0.8		1.3				
D 11. 0090. 00 R/L			○	○	0.93	0.9		1.5				
D 11. 0100. 00 R/L			○	○	1.00	-						
D 11. 0110. 00 R/L			○	○	1.20	1.1						
D 11. 0130. 00 R/L			○	○	1.40	1.3						
D 11. 0150. 00 R/L			○	○	1.50	-	11.0		6.7	-	8.0	4.2
D 11. 0160. 00 R/L			○	○	1.70	1.6		2.3				
D 11. 0200. 00 R/L			○	○	2.00							
D 11. 0250. 00 R/L			○	○	2.50	-						
D 11. 0300. 00 R/L			○	○	3.00							
D 11. 0200. 02 R/L			○	○	2.00	-				0,2		

Ausführung R oder L angeben / state R or L version

R = rechts, wie gezeichnet R = RH version shown

L = links, spiegelbildlich L = LH version, mirror image

Stechdrehen und NC-Feindrehen

Grooving and NC-Profiling

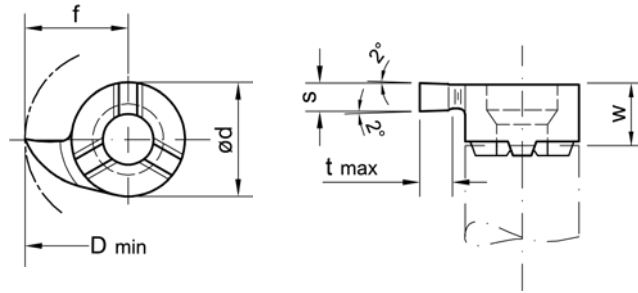

Bezeichnung Part Number	Lager Stock				Maße [mm] Dimensions							
	GK 1120		GK 5120		S _{+0,03}	Nuttennbreite Circlip	ØD _{min}	t _{max}	f	r	ød	w
	R	L	R	L								
D 14. 0070. 00 R/L			○	○	0.73	0.7		1.2				
D 14. 0080. 00 R/L			○	○	0.83	0.8		1.3				5.4
D 14. 0090. 00 R/L			○	○	0.93	0.9		1.5				
D 14. 0110. 00 R/L			○	○	1.20	1.1						
D 14. 0130. 00 R/L			○	○	1.40	1.3	14.0		9.0			
D 14. 0150. 00 R/L			○	○	1.50	-						
D 14. 0160. 00 R/L			○	○	1.70	1.6		4.0				5.3
D 14. 0200. 00 R/L			○	○	2.00							
D 14. 0250. 00 R/L			○	○	2.50							
D 14. 0300. 00 R/L			○	○	3.00							
D 14. 0150. 00. 16 R/L			○	○	1.50						9.0	
D 14. 0200. 00. 16 R/L			○	○	2.00		16.0	5.5	10.5			
D 14. 0250. 00. 16 R/L			○	○	2.50							
D 14. 0300. 00. 16 R/L			○	○	3.00							5.2
D 14. 0150. 00. 17 R/L			○	○	1.50	-						
D 14. 0200. 00. 17 R/L			○	○	2.00							
D 14. 0250. 00. 17 R/L			○	○	2.50		17.0	6.5	11.5			
D 14. 0300. 00. 17 R/L			○	○	3.00							
D 14. 0200. 02 R/L			○	○	2.00		14.0	4.0	9.0			5.3
D 14. 0200. 02. 16 R/L			○	○	2.00					0.2		
D 14. 0250. 02. 16 R/L			○	○	2.50		16.0	5.5	10.5			5.2
D 14. 0300. 02. 16 R/L			○	○	3.00							

Ausführung R oder L angeben / state R or L version
 R = rechts, wie gezeichnet R = RH version shown
 L = links, spiegelbildlich L = LH version, mirror image

Drehen
Turning

Fräswerkzeuge
Milling Tools

HDS-/VHM-Fräser
HDS-/Solid Carbide
Endmills

Stech- und
Abstechwerkzeuge
Grooving and
Parting off Tools

Mini/Micro
Schneidwerkzeuge
Mini/Micro Tools

Gewinde-
werkzeuge
Threading Tools

Wendepflanzenbohrer
VHM-Bohrer
Indexable Drills
Solid Carbide Drills

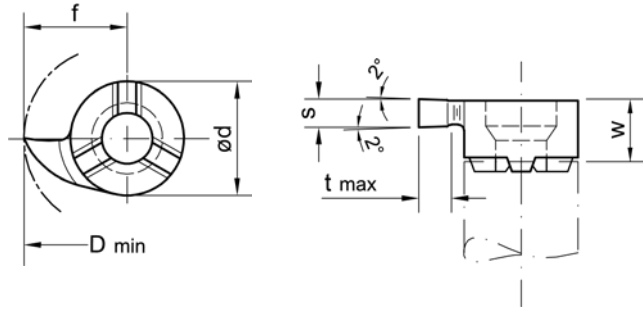

Bezeichnung Part Number	Lager Stock				Maße [mm] Dimensions							
	GK 1120		GK 5120		$s_{\pm 0,03}$	Nutenbreite Circip	\varnothing_{\min}	t_{\max}	f	r	ød	w
	R	L	R	L								
D 16. 0070. 00 R/L			○	○	0.73	0.7		1.2				
D 16. 0080. 00 R/L			○	○	0.83	0.8		1.3				5.5
D 16. 0090. 00 R/L			○	○	0.93	0.9		1.5				
D 16. 0110. 00 R/L			○	○	1.20	1.1						
D 16. 0130. 00 R/L			○	○	1.40	1.3						
D 16. 0150. 00 R/L			○	○	1.50	-						
D 16. 0160. 00 R/L			○	○	1.70	1.6	16.0		10.2	-	11.0	
D 16. 0200. 00 R/L			○	○	2.00			4.3				5.4
D 16. 0250. 00 R/L			○	○	2.50							
D 16. 0300. 00 R/L			○	○	3.00							
D 16. 0350. 00 R/L			○	○	3.50							
D 16. 0400. 00 R/L			○	○	4.00							
D 16. 0200. 02 R/L			○	○	2.00					0,2		

Ausführung R oder L angeben / state R or L version

R = rechts, wie gezeichnet R = RH version shown

L = links, spiegelbildlich L = LH version, mirror image

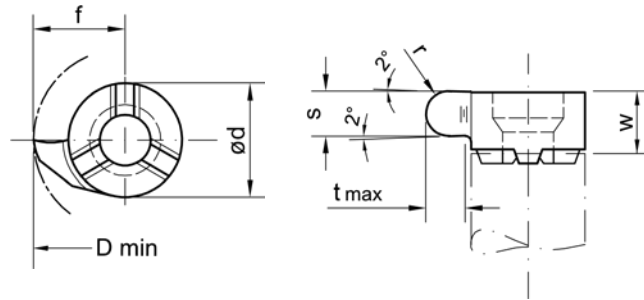
Stechdrehen / Vollradius
Grooving / Full Radius

Bezeichnung Part Number	Lager Stock				Maße [mm] Dimensions						
	GK 1120		GK 5120		$S_{+0,05}$	r	$\varnothing D_{min}$	t_{max}	f	$\varnothing d$	w
	R	L	R	L							
D 08. 0004. 08 R/L			○	○	0.8	0.4					
D 08. 0006. 12 R/L			○	○	1.2	0.6	8.0	1.0	4.8	6.0	3.3
D 08. 0009. 18 R/L			○	○	1.8	0.9					
D 10. 0004. 08 R/L			○	○	0.8	0.4					
D 10. 0006. 12 R/L			○	○	1.2	0.6					
D 10. 0009. 18 R/L			○	○	1.8	0.9	10.0	1.8	5.8	7.0	3.9
D 10. 0010. 20 R/L			○	○	2.0	1.0					
D 11. 0004. 08 R/L			○	○	0.8	0.4					
D 11. 0006. 12 R/L			○	○	1.2	0.6					
D 11. 0009. 18 R/L			○	○	1.8	0.9	11.0	2.3	6.7	8.0	4.2
D 11. 0010. 20 R/L			○	○	2.0	1.0					
D 11. 0015. 30 R/L			○	○	3.0	1.5					
D 14. 0006. 12 R/L			○	○	1.2	0.6					
D 14. 0009. 18 R/L			○	○	1.8	0.9					
D 14. 0010. 20 R/L			○	○	2.0	1.0	14.0	4.0	5.3	9.0	4.0
D 14. 0011. 22 R/L			○	○	2.2	1.1					
D 14. 0015. 30 R/L			○	○	3.0	1.5					
D 16. 0009. 18 R/L			○	○	1.8	0.9					
D 16. 0011. 22 R/L			○	○	2.2	1.1	16.0	4.3	10.2	11.0	5.4
D 16. 0015. 30 R/L			○	○	3.0	1.5					
D 16. 0020. 40 R/L			○	○	4.0	2.0					

Ausführung R oder L angeben / state R or L version

R = rechts, wie gezeichnet R = RH version shown

L = links, spiegelbildlich L = LH version, mirror image

Drehen
Turning

Fräswerkzeuge
Milling Tools

HDS-/VHM-Fräser
HDS-/Solid Carbide
Endmills

Stech- und
Abstechwerkzeuge
Grooving and
Parting off Tools

Mini/ Micro
Schneidwerkzeuge
Mini/ Micro Tools

Gewinde-
werkzeuge
Threading Tools

Wendepaltenbohrer
VHM-Bohrer
Indexable Drills
Solid Carbide Drills

Ausdrehen / Kopieren

Boring / Copying

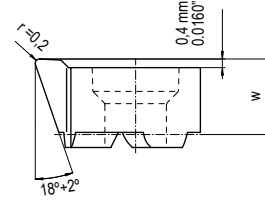
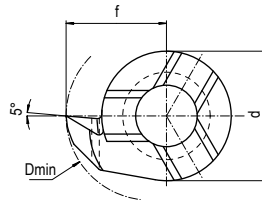

Bezeichnung Part Number	Lager Stock				Maße [mm] Dimensions			
	GK 1120		GK 5120		ØD _{min}	f	ød	w
	R	L	R	L				
D 08. 1846. 02 R/L			○	○	7.8	4.65	6.0	3.5
D 10. 1856. 02 R/L			○	○	10.0	5.60	7.0	3.9
D 11. 1855. 02 R/L			○	○	9.8	5.50	8.0	4.2
D 11. 1867. 02 R/L			○	○	11.0	6.70	8.0	4.2
D 14. 1887. 02 R/L			○	○	13.8	8.70	9.0	5.3
D 16. 1897. 02 R/L			○	○	15.5	9.70	11.0	5.4

Ausführung R oder L angeben / state R or L version

Ausdrehen / Freistechen 40°

Boring / Profiling 40°

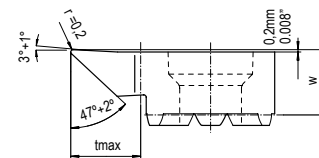
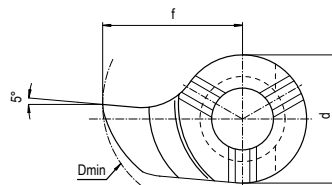

Bezeichnung Part Number	Lager Stock				Maße [mm] Dimensions				
	GK 1120		GK 5120		ØD _{min}	t _{max}	f	ød	w
	R	L	R	L					
D 08. 4746. 02 R/L			○	○	7.8	1.2	4.65	6.0	3.5
D 10. 4758. 02 R/L			○	○	10.0	1.8	5.80	7.0	3.9
D 11. 4767. 02 R/L			○	○	11.0	2.3	6.70	8.0	4.2
D 14. 4787. 02 R/L			○	○	13.7	3.0	8.70	9.0	5.3
D 16. 4702. 02 R/L			○	○	15.8	4.3	10.20	11.0	5.4

Ausführung R oder L angeben / state R or L version

R = rechts, wie gezeichnet
 R = RH version shown
 L = links, spiegelbildlich
 L = LH version, mirror image

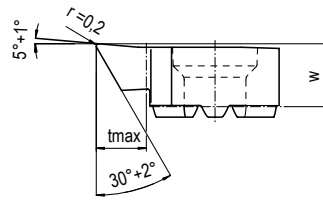
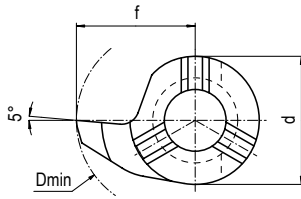
Ausdrehen / Freistechen 40° Boring / Profiling 40°
Ausdrehen / Freistechen 40° Boring / Profiling 40°

 Drehen
Turning

 Fräswerkzeuge
Milling Tools

 HDS-/VHM-Fräser
HDS-/Solid Carbide
Endmills

 Stech- und
Abstechwerkzeuge
Grooving and
Parting off Tools

 Mini/ Micro
Schneidwerkzeuge
Mini/ Micro Tools

 Gewinde-
werkzeuge
Threading Tools

 Wendepaltenbohrer
VHM-Bohrer
Indexable Drills
Solid Carbide Drills

Bezeichnung Part Number	Lager Stock				Maße [mm] Dimensions				
	GK 1120		GK 5120		ØD _{min}	t _{max}	f	ød	w
	R	L	R	L					
D 08. 2555. 02 R/L			○	○	7.8	1.0	4.65	6.0	3.5
D 11. 2755. 02 R/L			○	○	11.0	2.3	6.70	8.0	4.2
D 14. 3555. 02 R/L			○	○	13.7	4.0	8.70	9.0	5.3
D 16. 4055. 02 R/L			○	○	15.8	4.3	10.20	11.0	5.4

Ausführung R oder L angeben / state R or L version

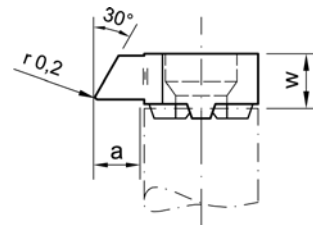
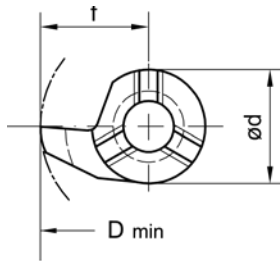
Rückwärtsdrehen
Boring by Backward Motion

Bezeichnung Part Number	Lager Stock				Maße [mm] Dimensions				
	GK 1120		GK 5120		ØD _{min}	a	f	ød	w
	R	L	R	L					
D 08. 3046. 02 R/L			○	○	7.8	1.3	4.65	6.0	3.5
D 10. 3068. 02. 11 R/L			○	○	11.0	2.6	6.8	7.0	4.0
D 11. 3067. 02 R/L			○	○	11.0	2.3	6.7	8.0	4.3
D 14. 3087. 02 R/L			○	○	13.8	3.5	8.7	9.0	5.4

Ausführung R oder L angeben / state R or L version

 R = rechts, wie gezeichnet
 R = RH version shown
 L = links, spiegelbildlich
 L = LH version, mirror image

Fasen / Ausdrehen

Chamfering / Boring

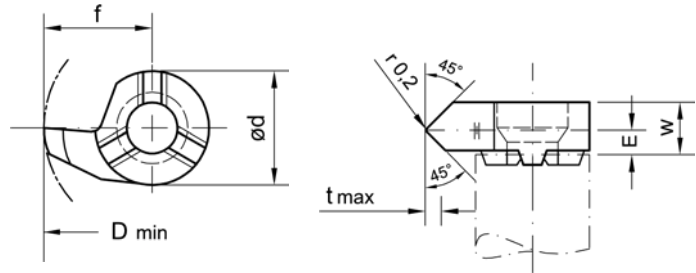

Bezeichnung Part Number	Lager Stock				Maße [mm] Dimensions					
	GK 1120		GK 5120		ØD _{min}	t _{max}	E	f	ød	w
	R	L	R	L						
D 08. 4545. 02 R/L			○	○	8.0	1.4	1.8	4.8	6.0	3.5
D 10. 4545. 02 R/L			○	○	10.0	1.5	2.0	5.8	7.0	4.0
D 11. 4545. 02 R/L			○	○	11.0	1.5	2.2	6.7	8.0	4.3
D 14. 4545. 02 R/L			○	○	14.0	1.5	2.8	9.0	9.0	5.4

Ausführung R oder L angeben / state R or L version

Vorstechen / Fasen

Pregrooving / Chamfering

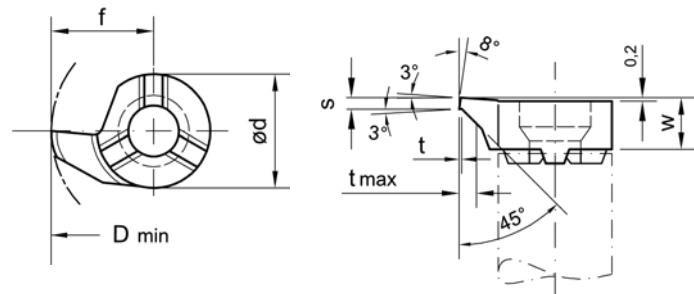

Bezeichnung Part Number	Lager Stock				Maße [mm] Dimensions						
	GK 1120		GK 5120		s	ØD _{min}	t	t _{max}	f	ød	w
	R	L	R	L							
D 08. 0810. 00 R/L			○	○	1.0	8.0	0.2	1.0	4.8	6.0	3.3
D 10. 0810. 00 R/L			○	○	1.0	10.0	0.2	1.5	5.8	7.0	3.9
D 11. 0810. 00 R/L			○	○	1.0	11.0	0.2	1.5	6.7	8.0	4.2
D 14. 0810. 00 R/L			○	○	1.0	14.0	0.2	1.5	9.0	9.0	5.3
D 16. 0810. 00 R/L			○	○	1.0	16.0	0.2	1.5	10.2	11.0	5.4

Ausführung R oder L angeben / state R or L version

R = rechts, wie gezeichnet
 R = RH version shown
 L = links, spiegelbildlich
 L = LH version, mirror image

Gewindedrehen, metrisch 60°, Teilprofil

threading, metric 60°, partial profile

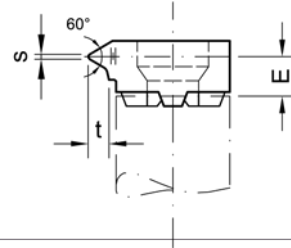
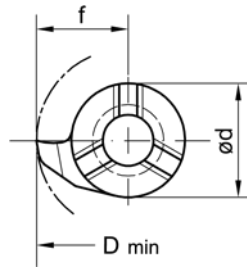

Bezeichnung Part Number	Lager Stock				Maße [mm] Dimensions						
	GK 1120		GK 5120		Steigung Pitch	s	ØD _{min}	t	E	f	ød
	R	L	R	L							

REGELGEWINDE / STANDARD METRIC THREAD

D 08. 0815. 01 R/L			○ ○	1.5/1.75	0.18	8.0	0.95	2.5	4.8	6.0
D 11. 1020. 01 R/L			○ ○	2.0	0.25	11.0	1.08	3.0	6.7	8.0
D 11. 1325. 01 R/L			○ ○	2.5	0.31	14.0	1.35	3.0	9.0	9.0
D 14. 1020. 01 R/L			○ ○	2.0	0.25	14.0	1.08	4.2	9.0	9.0
D 14. 1325. 01 R/L			○ ○	2.5	0.31	16.0	1.35	4.7	10.2	11.0
D 16. 1325. 01 R/L			○ ○	2.5	0.31	16.0	1.35	4.2	10.2	11.0

FEINGEWINDE / FINE THREAD

D 08. 0205. 01 R/L			○ ○	0.5/0.75	0.06	8.0	0.43	2.7	4.8	6.0
D 08. 0510. 01 R/L			○ ○	1.0/1.25	0.12	11.0	0.70	3.5	6.7	8.0
D 11. 0205. 01 R/L			○ ○	0.5/0.75	0.06	11.0	0.55	3.5	6.7	8.0
D 11. 0510. 01 R/L			○ ○	1.0	0.12	14.0	0.55	4.7	9.0	9.0
D 11. 0815. 01 R/L			○ ○	1.5	0.18	16.0	0.81	4.5	10.2	11.0
D 14. 0510. 01 R/L			○ ○	1.0	0.12	16.0	0.81	4.5	10.2	11.0
D 14. 0815. 01 R/L			○ ○	1.5	0.18	16.0	0.81	4.5	10.2	11.0
D 16. 0510. 01 R/L			○ ○	1.0	0.12	16.0	0.81	4.5	10.2	11.0
D 16. 0815. 01 R/L			○ ○	1.5	0.18	16.0	0.81	4.5	10.2	11.0
D 16. 1020. 01 R/L			○ ○	2.0	0.25	16.0	1.08	4.2	10.2	11.0

Ausführung R oder L angeben / state R or L version
 R = rechts, wie gezeichnet R = RH version shown
 L = links, spiegelbildlich L = LH version, mirror image

Drehen
Turning

Fräswerkzeuge
Milling Tools

HDS-/VHM-Fräser
HDS-/Solid Carbide
Endmills

Stech- und
Abstechwerkzeuge
Grooving and
Parting off Tools

Mini/ Micro
Schneidwerkzeuge
Mini/ Micro Tools

Gewinde-
werkzeuge
Threading Tools

Wendepplattenbohrer
VHM-Bohrer
Indexable Drills
Solid Carbide Drills

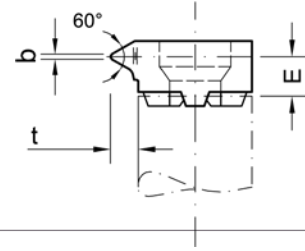
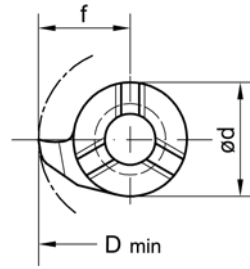
Gewindedrehen, metrisch 60°, Vollprofil
Threading, Metric 60°, Full Profile

Bezeichnung Part Number	Lager Stock				Maße [mm] Dimensions						
	GK 1120		GK 5120		Steigung Pitch	b	ØD _{min}	t	E	f	ød
	R	L	R	L							

REGELGEWINDE / STANDARD METRIC THREAD

D 11. 1020. 02 R/L			○ ○	2.0	0.25		1.08	3.2			
D 11. 1325. 02 R/L			○ ○	2.5	0.31	11.0	1.35	3.0	6.7	8.0	
D 11. 1630. 02 R/L			○ ○	3.0	0.37		1.62	2.9			
D 14. 1020. 02 R/L			○ ○	2.0	0.25	14.0	1.08	4.2		9.0	9.0
D 14. 1325. 02 R/L			○ ○	2.5	0.31		1.35	4.7			
D 16. 1325. 02 R/L			○ ○	2.5	0.31		1.35	4.2			
D 16. 1630. 02 R/L			○ ○	3.0	0.37	16.0	1.62	4.0		10.2	11.0
D 16. 1835. 02 R/L			○ ○	3.5	0.43		1.89	3.8			
D 16. 2140. 02 R/L			○ ○	4.0	0.50		2.16	3.6			

FEINGEWINDE / FINE THREAD

D 11. 0510. 02 R/L			○ ○	1.0	0.12	11.0	0.54		3.5	6.7	8.0
D 11. 0815. 02 R/L			○ ○	1.5	0.18		0.81				
D 14. 0205. 02 R/L			○ ○	0.5	0.06		0.27	4.7			
D 14. 0510. 02 R/L			○ ○	1.0	0.12	14.0	0.54	4.7		9.0	9.0
D 14. 0815. 02 R/L			○ ○	1.5	0.18		0.81	4.5			
D 16. 0510. 02 R/L			○ ○	1.0	0.12		0.54	4.7			
D 16. 0815. 02 R/L			○ ○	1.5	0.18	16.0	0.81	4.5		10.2	11.0
D 16. 1020. 02 R/L			○ ○	2.0	0.25		1.08	4.2			

Ausführung R oder L angeben / state R or L version

R = rechts, wie gezeichnet R = RH version shown

L = links, spiegelbildlich L = LH version, mirror image

Gewindedrehen, BSW 55°, Vollprofil

Threading, BSW 55°, Full Profile

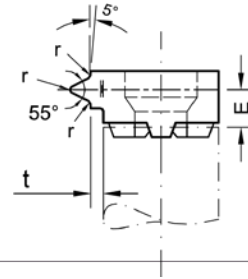
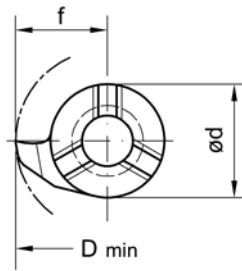

Bezeichnung Part Number	Lager Stock				Maße [mm] Dimensions						
	GK 1120		GK 5120		Steigung Pitch	r	ØD _{min}	t	E	f	ød
	R	L	R	L							
D 11. 0813. 19 R/L			○	○	19	0.18		0.85	2.7		
D 11. 1118. 14 R/L			○	○	14	0.24	11.0	1.16	3.0	6.7	8.0
D 14. 0813. 19 R/L			○	○	19	0.18		0.85	3.9		
D 14. 1118. 14 R/L			○	○	14	0.24	14.0	1.16	3.6	9.0	9.0
D 16. 1118. 14 R/L			○	○	14	0.24		1.16	3.9		
D 16. 1423. 11 R/L			○	○	11	0.31	16.0	1.48	3.5	10.2	11.0

Ausführung R oder L angeben / state R or L version

Gewindedrehen, Trapez DIN103, ACME

Threading, Trapez DIN103, ACME

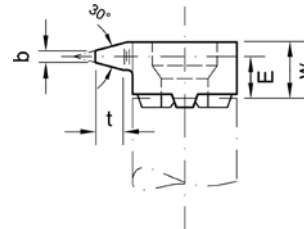
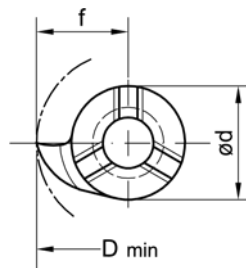

Bezeichnung Part Number	Lager Stock				Maße [mm] Dimensions							
	GK 1120		GK 5120		Steigung Pitch	b	ØD _{min}	E	f	ød	w	t
	R	L	R	L								
D 11. 1015. 01 R/L			○	○	1.5	0.47		3.7				0.9
D 11. 1220. 01 R/L			○	○	2.0	0.60	11.0	3.5	6.7	8.0	4.3	1.25
D 11. 1730. 01 R/L			○	○	3.0	0.96		3.2				1.75
D 14. 1220. 01 R/L			○	○	2.0	0.60		4.3				1.25
D 14. 1730. 01 R/L			○	○	3.0	0.96		4.0				1.75
D 14. 2240. 01 R/L			○	○	4.0	1.33	14.0	3.6	9.0	9.0	5.3	2.25
D 14. 2750. 01 R/L			○	○	5.0	1.69		3.3				2.75
D 16. 1220. 01 R/L			○	○	2.0	0.60		4.5				1.25
D 16. 1730. 01 R/L			○	○	3.0	0.96		4.3	9.7			1.75
D 16. 2240. 01 R/L			○	○	4.0	1.33	16.0	4.0		11.0	5.5	2.25
D 16. 2750. 01 R/L			○	○	5.0	1.69		3.55	10.2			2.75

Ausführung R oder L angeben / state R or L version

R = rechts, wie gezeichnet R = RH version shown

L = links, spiegelbildlich L = LH version, mirror image

Axialstechen

Face Grooving

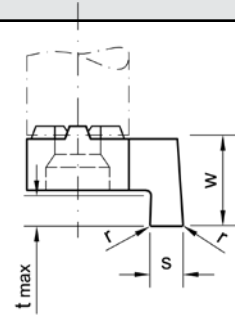
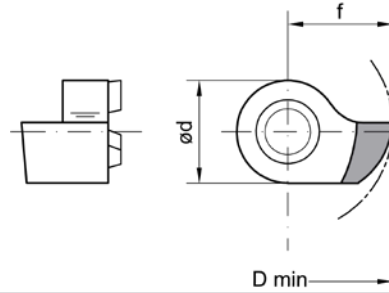

Bezeichnung Part Number	Lager Stock				Maße [mm] Dimensions						
	GK 1120		GK 5120		$s_{+0,03}$	$\varnothing D_{min}$	t_{max}	r	f	$\varnothing d$	w
	R	L	R	L							
D 14. 1410. 00 R/L			o	o	1.0		1.5	-			8.3
D 14. 1415. 02 R/L			o	o	1.5		2.5				8.3
D 14. 1420. 02 R/L			o	o	2.0		3.0				8.3
D 14. 1420. 52 R/L			o	o	2.0		5.0				10.3
D 14. 1425. 02 R/L			o	o	2.5	14.0	3.0	0.2	9.0	9.0	8.3
D 14. 1425. 52 R/L			o	o	2.5		5.0				10.3
D 14. 1430. 02 R/L			o	o	3.0		3.0				8.3
D 14. 1430. 52 R/L			o	o	3.0		5.0				10.3

Ausführung R oder L angeben / state R or L version

Axialstechen, Kontra-Version

Face Grooving, Contra-Version

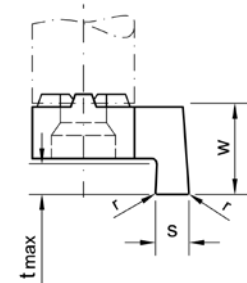
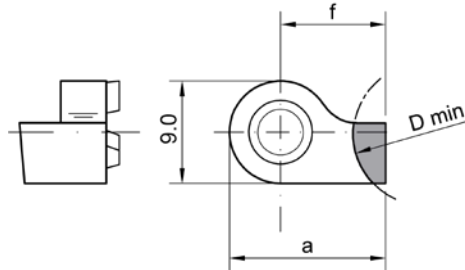

Bezeichnung Part Number	Lager Stock				Maße [mm] Dimensions						
	GK 1120		GK 5120		$s_{+0,03}$	$\varnothing D_{min}$	t_{max}	r	a	f	w
	R	L	R	L							
D 14. 1210. 00 R/L			o	o	1.0		1.5	-	11.5	7.0	8.3
D 14. 1215. 02 R/L			o	o	1.5		2.5		12.0	7.5	8.3
D 14. 1220. 02 R/L			o	o	2.0		3.0		12.5	8.0	8.3
D 14. 1220. 52 R/L			o	o	2.0		5.0				10.3
D 14. 1225. 02 R/L			o	o	2.5	14.0	3.0	0.2	13.0	8.5	8.3
D 14. 1225. 52 R/L			o	o	2.5		5.0				10.3
D 14. 1230. 02 R/L			o	o	3.0		3.0		13.5	9.0	8.3
D 14. 1230. 52 R/L			o	o	3.0		5.0				10.3

Ausführung R oder L angeben / state R or L version

Schnittgeschwindigkeits-Empfehlungen für Mini-Schneidwerkzeuge

Cutting Speed Recommendations for Mini Cutting Tools

	Werkstückwerkstoff <i>Material</i>	Legierung <i>Alloy</i>	Schnittgeschwindigkeiten v_c [m/min] <i>Cutting Speeds v_c [m/min]</i>	
			GK 1120 (K20F)	GK 5120 (K20F-TiN)
A (P)	Unlegierter Stahl <i>Mild steel</i>	geglüht / <i>annealed</i> < 0,15% C	-	140 - 220
		geglüht / <i>annealed</i> 0,15% - 0,45% C	30 - 100	110 - 200
		vergütet / <i>heat treated</i> > 0,45% C	-	100 - 180
	Legierter Stahl <i>Alloy steel</i>	niedrig / <i>low</i>	-	110 - 200
		mittel / <i>medium</i>	30 - 80	90 - 160
		hoch / <i>high</i>	-	30 - 100
R (M)	Rostfreier Stahl <i>Stainless steel</i>	austenitisch / <i>austenitic</i>	40 - 80	40 - 160
		martensitisch / <i>martensitic</i>	40 - 80	40 - 160
F (K)	Stahlguss <i>Cast iron</i>	unlegiert / <i>unalloyed</i>	-	100 - 160
		legiert / <i>alloyed</i>	-	40 - 110
	Grauguss <i>Grey cast iron</i>		50 - 90	50 - 160
N	Aluminium		100 - 500	50 - 800
	Bronze, Messing, Rotguss <i>Bronze, brass, red brass</i>		90 - 180	-
S	Nickel-Basis <i>Nickel base</i>		20 - 60	-

Vorschub Einstechen <i>Feed Turning</i>	0,01 - 0,03 mm / U mm / rev.
Vorschub Ausdrehen <i>Feed Turning</i>	0,03 - 0,10 mm / U mm / rev.

Die Verwendung von Kühlschmiermitteln wird empfohlen.

Drehen
Turning

Fräswerkzeuge
Milling Tools

HDS-/VHM-Fräser
HDS-/ Solid Carbide
Endmills

Stech- und
Abstechwerkzeuge
Grooving and
Parting off Tools

Mini/Micro
Schneidwerkzeuge
Mini/ Micro Tools

Gewinde-
werkzeuge
Threading Tools

Wendepplattenbohrer
VHM-Bohrer
Indexable Drills
Solid Carbide Drills

		Seite Page
Micro - Klemmhalter Micro - Toolholders		5.20
Micro-Schneideinsätze (Feinkorn-Hartmetall) zum Micro-Inserts (Micro Grain Carbide) for		
Kopierdrehen / Copying 35°	 ≥ 4.2 mm	5.22
Ausdrehen / Boring	 ≥ 0.3 mm	5.22
Ausdrehen / Boring	 ≥ 1.0 mm	5.23
Ausdrehen / Boring	 ≥ 5.2 mm	5.24
Nutenstechen / Grooving	 ≥ 4.2 mm	5.25
Nutenstechen / Grooving	 ≥ 6.2 mm	5.26
Nutenstechen / Grooving	 ≥ 7.2 mm	5.27
Ausdrehen und Fasen / Boring and Chamfering	 ≥ 5.2 mm	5.28
Vorstechen und Fasen / Pregrooving and Chamfering	 ≥ 5.2 mm	5.28
Stechen von Vollradiusnuten / Full Radius Grooving	 ≥ 4.2 mm	5.29
Ausdrehen / Boring 90°	 ≥ 3.2 mm	5.29
Gewindedrehen, Metrisch / Threading, Metric 60°	 ≥ 4.2 mm	5.30
Gewindedrehen, BSW / Threading, BSW 55°	 ≥ 5.2 mm	5.30
Gewindedrehen, UN / Threading, UN	 ≥ 4.2 mm	5.31
Gewindedrehen, NPT / Threading, NPT	 ≥ 6.2 mm	5.31
Axialstechen in Bohrungen Face Grooving in Bores	 ≥ 6.2 mm	5.32
Axialstechen am Zapfen Face Grooving on Pivots	 ≥ 6.2 mm	5.33
Axialstechen in Bohrungen Face Grooving in Bores	 ≥ 16/10 mm ≥ 20/12 mm	5.34
Schnittdaten - Empfehlungen / Schneidstoffe Cutting Data Recommendations / Carbide Grades		5.35

Drehen
Turning

Fräswerkzeuge
Milling Tools

HDS-/VHM-Fräser
HDS-/Solid Carbide
Endmills

Stech- und
Abstechwerkzeuge
Grooving and
Parting off Tools

Mini/Micro
Schneidwerkzeuge
Mini/Micro Tools

Gewinde-
werkzeuge
Threading Tools

Wendepaltenbohrer
VHM-Bohrer
Indexable Drills
Solid Carbide Drills

820-D

Runder Schaft Round Shank

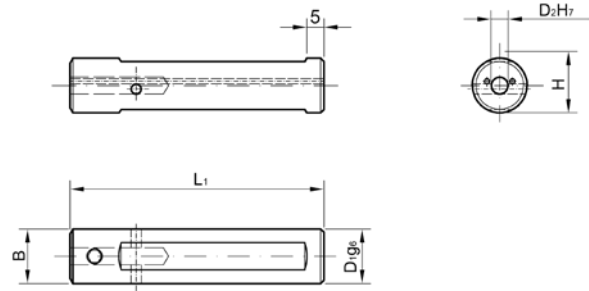

Drehen
Turning

Fräswerkzeuge
Milling Tools



HDS-/VHM-Fräser
HDS-/Solid Carbide
Endmills

Stech- und
Abstechwerkzeuge
Grooving and
Parting off Tools

Mini/Micro
Schneidwerkzeuge
Mini/ Micro Tools

Gewinde-
werkzeuge
Threading Tools

Wendepplattenbohrer
VHM-Bohrer
Indexable Drills
Solid Carbide Drills

Bezeichnung Part Number	Lager Stock	Maße [mm] Dimensions					Ersatzteile Spare Parts	
		D _{1g6}	D _{2H7}	B	H	L ₁		
820. 0010. 04 - D	○		4					
05 - D	○	10	5	10	8	65		
0012. 04 - D	○		4					
05 - D	○	12	5	12	10	70		
06 - D	○		6					
0016. 04 - D	○		4					
05 - D	○		5					
06 - D	○	16	6	16	14	75		
07 - D	○		7					
08 - D	○		8					
0020. 04 - D	○		4	20				
05 - D	○		5	20				
06 - D	○		6	22				
07 - D	○	20	7	22	18	90		
08 - D	○		8	25				
10 - D	○		10	25				
0500. 04 - D	○		4					
05 - D	○	1/2"	5	12.7	10.7	69.85	32.30.137	56.33.613
06 - D	○		6					
0625. 04 - D	○		4					
05 - D	○		5					
06 - D	○	5/8"	6	15.875	13.88	76.2		
07 - D	○		7					
08 - D	○		8					
0750. 04 - D	○		4	20				
05 - D	○		5	20				
06 - D	○		6	22				
07 - D	○	3/4"	7	22	17.05	110		
08 - D	○		8	25				
10 - D	○		10	25				
1000. 04 - D	○		4					
05 - D	○		5					
06 - D	○		6					
07 - D	○	1"	7	25.4	23.4	110		
08 - D	○		8					
10 - D	○		10					

825-D

Quadratischer Schaft Square Shank

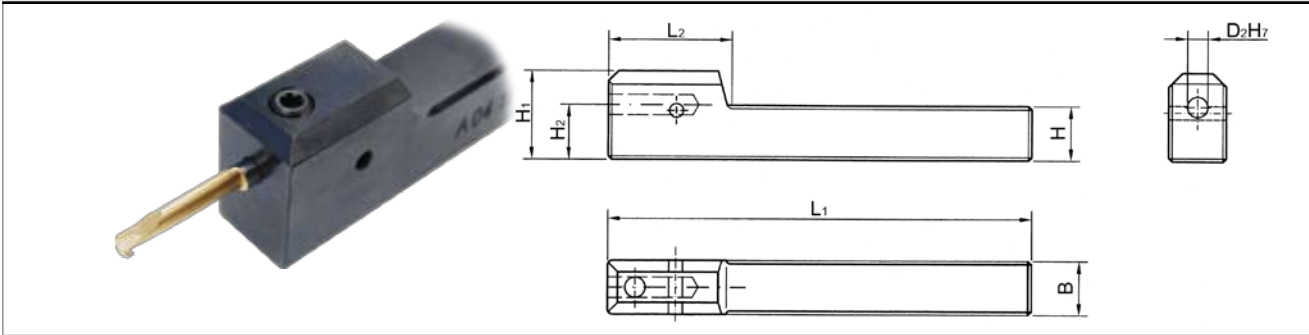

Bezeichnung Part Number	Lager Stock	Maße [mm] Dimensions							Ersatzteile Spare Parts		
		D ₂ H ₇	B	H	H ₁	H ₂	L ₁	L ₂			
825. 1010. 04 - D	○	4			19.0					32.30.137	56.33.613
05 - D	○	5	10	10	19.5	10	100	25			
825. 1212. 04 - D	○	4			21.0						
05 - D	○	5	12	12	21.5	12	100	27			
06 - D	○	6			22.0			27			
825. 1616. 04 - D	○	4			25.0			25			
05 - D	○	5			25.5			35			
06 - D	○	6	16	16	26.0	16	125	35			
07 - D	○	7			26.5			35			
08 - D	○	8			27.0			40			
825. 2020. 04 - D	○	4			29.0			25			
05 - D	○	5			29.5			35			
06 - D	○	6			30.0			35			
07 - D	○	7	20	20	30.5	20	125	35			
08 - D	○	8			31.0			35			
10 - D	○	10			32.0			35			

Sonderausführungen auf Anfrage / Special dimensions upon request

Drehen
Turning

Fräswerkzeuge
Milling Tools

HDS-/VHM-Fräser
HDS-/Solid Carbide
Endmills

Stech- und
Abstechwerkzeuge
Grooving and
Parting off Tools

Mini/ Micro
Schneidwerkzeuge
Mini/ Micro Tools

Gewinde-
werkzeuge
Threading Tools

Wendepplattenbohrer
VHM-Bohrer
Indexable Drills
Solid Carbide Drills

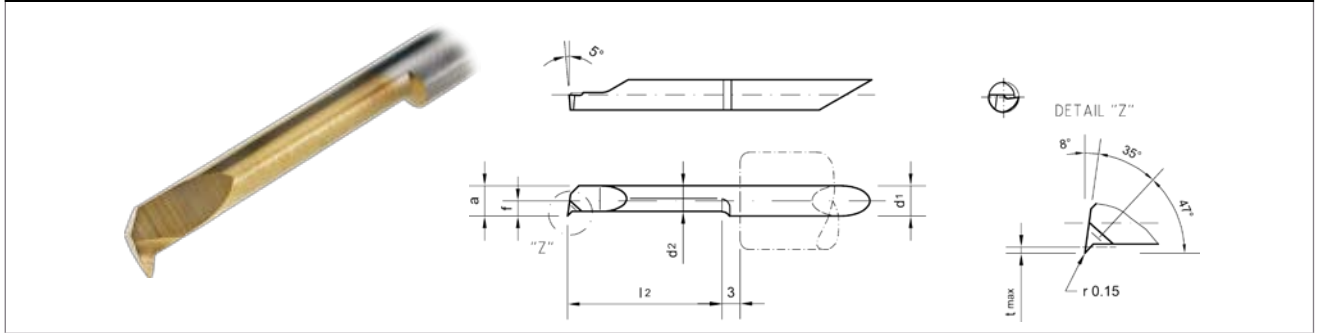
Kopierdrehen 35°, Dmin 4.2 mm
Copying 35°, Dmin 4.2 mm

Bezeichnung Part Number	Lager Stock				Maße [mm] Dimensions						
	GK 1120		GK 5120		f	d ₂	a	l ₂	t _{max}	D _{min}	d ₁
	R	L	R	L							
R/L 804. 35. 20. 42 -D			○	○	1.95	2.95	3.95	20	0.8	4.2	4.0
R/L 805. 35. 25. 52 -D			○	○	2.45	3.75	4.95	25	1.0	5.2	5.0
R/L 806. 35. 30. 62 -D			○	○	2.95	3.95	5.95	30	1.8	6.2	6.0

Ausführung R oder L angeben / state R or L version

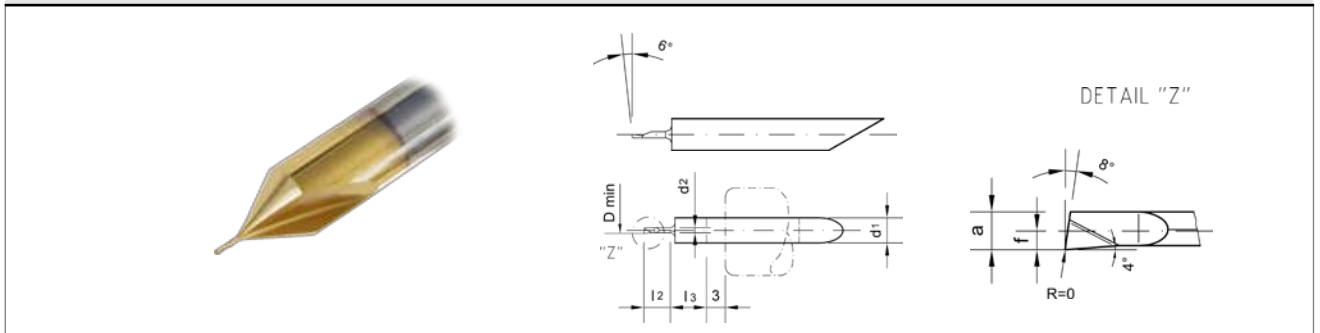
Ausdrehen Dmin 0.3 mm
Boring Dmin 0.3 mm

Bezeichnung Part Number	Lager Stock				Maße [mm] Dimensions							
	GK 1120		GK 5120		f	d ₂ +0,03	a	l ₂	t _{max}	D _{min}	d ₁	l ₃
	R	L	R	L								
R/L 804. 61. 12. 03 -D			○	○	0.10	0.19	0.25	1.2	-	0.3		8.8
R/L 804. 61. 16. 04 -D			○	○	0.15	0.28	0.35	1.6	-	0.4		8.4
R/L 804. 61. 20. 05 -D			○	○	0.20	0.37	0.45	2.0	-	0.5		8.0
R/L 804. 61. 25. 06 -D			○	○	0.25	0.46	0.55	2.5	-	0.6	4.0	7.5
R/L 804. 61. 35. 07 -D			○	○	0.30	0.55	0.65	3.5	-	0.7		6.5
R/L 804. 61. 40. 08 -D			○	○	0.35	0.64	0.75	4.0	-	0.8		6.0
R/L 804. 61. 50. 09 -D			○	○	0.40	0.73	0.85	5.0	-	0.9		5.0

Ausführung R oder L angeben / state R or L version

R = rechts, wie gezeichnet R = RH version shown

L = links, spiegelbildlich L = LH version, mirror image

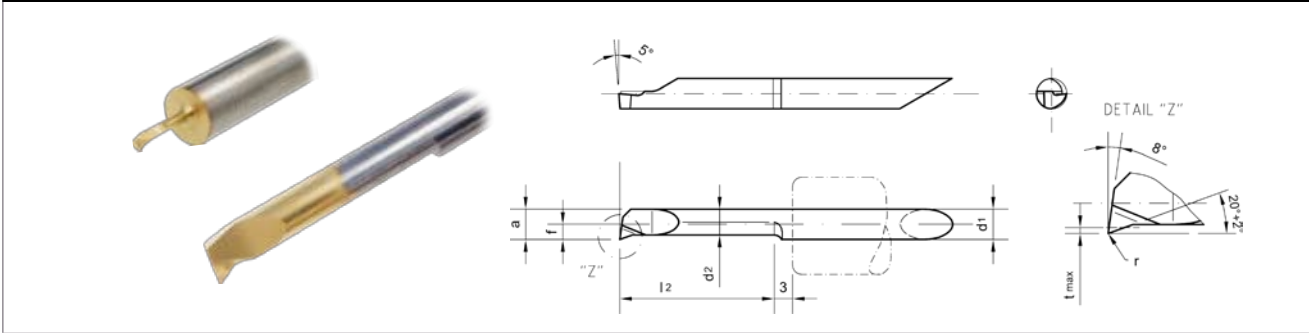
Ausdrehen Dmin 1.0 mm
Boring Dmin 1.0 mm

Bezeichnung Part Number	Lager Stock				Maße [mm] Dimensions							
	GK 1120		GK 5120		f	d ₂	a	l ₂	t _{max}	D _{min}	d ₁	r
	R	L	R	L								
R/L 804. 62. 04. 10 -D			○	○	0.45	0.65	0.95	4	0.1	1.0		
R/L 804. 62. 06. 10 -D			○	○				6				
R/L 804. 62. 06. 17 -D			○	○	0.70	1.05	1.45	6		1.7		
R/L 804. 62. 09. 17 -D			○	○				9				0.10
R/L 804. 62. 06. 22 -D			○	○				6				
R/L 804. 62. 09. 22 -D			○	○	0.95	1.55	1.95	9		2.2		
R/L 804. 62. 13. 22 -D			○	○				13				
R/L 804. 62. 10. 27 -D			○	○	1.20	2.05	2.45	10		2.7		
R/L 804. 62. 15. 27 -D			○	○				15	0.2			
R/L 804. 62. 10. 32 -D			○	○				10			4.0	
R/L 804. 62. 15. 32 -D			○	○	1.45	2.55	2.95	15		3.2		
R/L 804. 62. 20. 32 -D			○	○				20				
R/L 804. 62. 10. 37 -D			○	○				10				
R/L 804. 62. 15. 37 -D			○	○	1.70	3.05	3.45	15		3.7		0.15
R/L 804. 62. 20. 37 -D			○	○				20				
R/L 804. 62. 10. 42 -D			○	○				10				
R/L 804. 62. 15. 42 -D			○	○				15				
R/L 804. 62. 20. 42 -D			○	○	1.95	3.45	3.95	20	0.3	4.2		
R/L 804. 62. 25. 42 -D			○	○				25				

Ausführung R oder L angeben / state R or L version
 R = rechts, wie gezeichnet R = RH version shown
 L = links, spiegelbildlich L = LH version, mirror image

 Drehen
Turning

 Fräswerkzeuge
Milling Tools

 HDS-/VHM-Fräser
HDS-/Solid Carbide
Endmills

 Stech- und
Abstechwerkzeuge
Grooving and
Parting off Tools

 Mini/ Micro
Schneidwerkzeuge
Mini/ Micro Tools

 Gewinde-
werkzeuge
Threading Tools

 Wendeplattenbohrer
VHM-Bohrer
Indexable Drills
Solid Carbide Drills

Ausdrehen Dmin 5.2 mm

Boring Dmin 5.2 mm

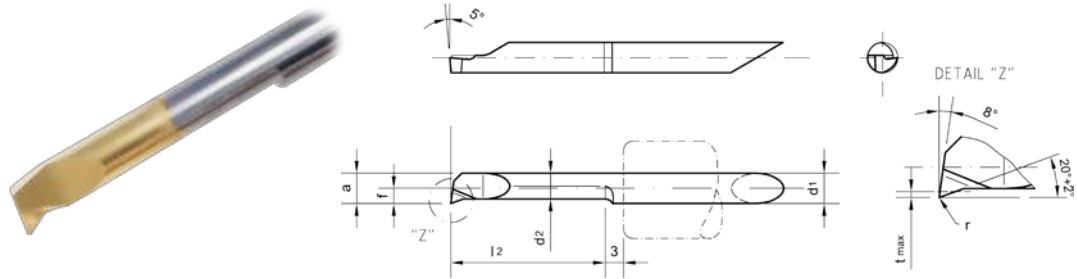

Bezeichnung Part Number	Lager Stock				Maße (mm) Dimensions						
	GK 1120		GK 5120		f	d ₂	a	l ₂	t _{max}	D _{min}	d ₁
	R	L	R	L							
R/L 805. 62. 10. 52 -D			○	○				10			
R/L 805. 62. 15. 52 -D			○	○				15			
R/L 805. 62. 20. 52 -D			○	○	2.45	4.25	4.95	20		5.2	5.0
R/L 805. 62. 25. 52 -D			○	○				25			
R/L 805. 62. 30. 52 -D			○	○				30			
R/L 806. 62. 15. 62 -D			○	○				15			
R/L 806. 62. 20. 62 -D			○	○				20			
R/L 806. 62. 25. 62 -D			○	○	2.95	5.25	5.95	25		6.2	6.0
R/L 806. 62. 30. 62 -D			○	○				30	0.5		
R/L 806. 62. 35. 62 -D			○	○				35			
R/L 806. 62. 40. 62 -D			○	○				40			
R/L 807. 62. 25. 72 -D			○	○				25			
R/L 807. 62. 30. 72 -D			○	○				30			
R/L 807. 62. 35. 72 -D			○	○	3.45	6.25	6.95	35		7.2	7.0
R/L 807. 62. 40. 72 -D			○	○				40			
R/L 807. 62. 45. 72 -D			○	○				45			
R/L 807. 62. 50. 72 -D			○	○				50			

Ausführung R oder L angeben / state R or L version

R = rechts, wie gezeichnet R = RH version shown

L = links, spiegelbildlich L = LH version, mirror image

Nutenstechen Dmin 4.2 mm

Grooving Dmin 4.2 mm

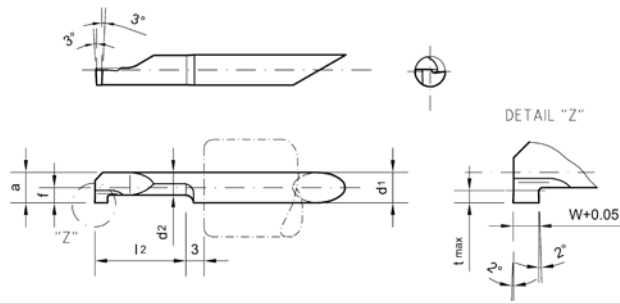

Bezeichnung Part Number	Lager Stock				Maße [mm] Dimensions							
	GK 1120		GK 5120		w	f	d ₂	a	l ₂	t _{max}	D _{min}	d ₁
	R	L	R	L								
R/L 804. 10. 10. 42 -D			○	○					10			
R/L 804. 10. 15. 42 -D			○	○	1.0	1.95	2.95	3.95	15	0.8	4.2	4.0
R/L 804. 10. 20. 42 -D			○	○					20			
R/L 805. 10. 10. 52 -D			○	○	1.0							
R/L 805. 15. 10. 52 -D			○	○	1.5				10			
R/L 805. 20. 10. 52 -D			○	○	2.0							
R/L 805. 10. 15. 52 -D			○	○	1.0							
R/L 805. 15. 15. 52 -D			○	○	1.5				15			
R/L 805. 20. 15. 52 -D			○	○	2.0							
R/L 805. 10. 20. 52 -D			○	○	1.0							
R/L 805. 15. 20. 52 -D			○	○	1.5				20			
R/L 805. 20. 20. 52 -D			○	○	2.0	2.45	3.75	4.95		1.0	5.2	5.0
R/L 805. 10. 25. 52 -D			○	○	1.0							
R/L 805. 15. 25. 52 -D			○	○	1.5				25			
R/L 805. 20. 25. 52 -D			○	○	2.0							
R/L 805. 10. 30. 52 -D			○	○	1.0							
R/L 805. 15. 30. 52 -D			○	○	1.5				30			
R/L 805. 20. 30. 52 -D			○	○	2.0							
R/L 805. 10. 35. 52 -D			○	○	1.0				35			

Ausführung R oder L angeben / state R or L version
 R = rechts, wie gezeichnet R = RH version shown
 L = links, spiegelbildlich L = LH version, mirror image

Drehen
Turning

Fräswerkzeuge
Milling Tools

HDS-/VHM-Fräser
HDS-/Solid Carbide
Endmills

Stech- und
Abstechwerkzeuge
Grooving and
Parting off Tools

Mini/ Micro
Schneidwerkzeuge
Mini/ Micro Tools

Gewinde-
werkzeuge
Threading Tools

Wendepflanzenbohrer
VHM-Bohrer
Indexable Drills
Solid Carbide Drills

Nutenstechen Dmin 6.2 mm

Grooving Dmin 6.2 mm

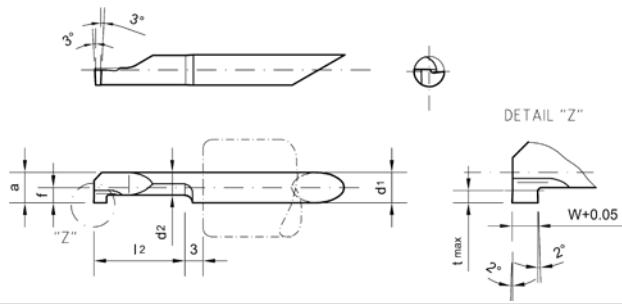

Bezeichnung Part Number	Lager Stock				Maße [mm] Dimensions							
	GK 1120		GK 5120		w	f	d ₂	a	l ₂	t _{max}	D _{min}	d ₁
	R	L	R	L								
R/L 806. 10. 10. 62 -D			○	○	1.0							
R/L 806. 15. 10. 62 -D			○	○	1.5				10			
R/L 806. 20. 10. 62 -D			○	○	2.0							
R/L 806. 10. 15. 62 -D			○	○	1.0							
R/L 806. 15. 15. 62 -D			○	○	1.5				15			
R/L 806. 20. 15. 62 -D			○	○	2.0							
R/L 806. 10. 20. 62 -D			○	○	1.0							
R/L 806. 15. 20. 62 -D			○	○	1.5				20			
R/L 806. 20. 20. 62 -D			○	○	2.0	2.95	3.95	5.95		1.8	6.2	6.0
R/L 806. 10. 25. 62 -D			○	○	1.0							
R/L 806. 15. 25. 62 -D			○	○	1.5				25			
R/L 806. 20. 25. 62 -D			○	○	2.0							
R/L 806. 10. 30. 62 -D			○	○	1.0							
R/L 806. 15. 30. 62 -D			○	○	1.5				30			
R/L 806. 20. 30. 62 -D			○	○	2.0							
R/L 806. 10. 35. 62 -D			○	○	1.0				35			
R/L 806. 15. 35. 62 -D			○	○	1.5							
R/L 806. 10. 40. 62 -D			○	○	1.0				40			

Ausführung R oder L angeben / state R or L version
 R = rechts, wie gezeichnet R = RH version shown
 L = links, spiegelbildlich L = LH version, mirror image

Nutenstechen Dmin 7.2 mm

Grooving Dmin 7.2 mm

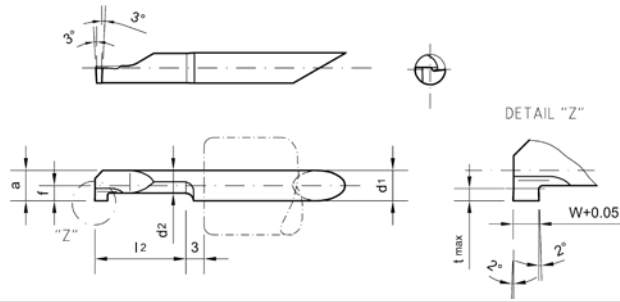

Drehen
Turning

Fräswerkzeuge
Milling Tools

HDS-/VHM-Fräser
HDS-/Solid Carbide
Endmills

Stech- und
Abstechwerkzeuge
Grooving and
Parting off Tools

Mini/ Micro
Schneidwerkzeuge
Mini/ Micro Tools

Gewinde-
werkzeuge
Threading Tools

Wendepflanzenbohrer
VHM-Bohrer
Indexable Drills
Solid Carbide Drills

Bezeichnung Part Number	Lager Stock				Maße [mm] Dimensions							
	GK 1120		GK 5120		w	f	d ₂	a	l ₂	t _{max}	D _{min}	d ₁
	R	L	R	L								
R/L 807. 10. 10. 72 -D			o	o	1.0							
R/L 807. 15. 10. 72 -D			o	o	1.5				10			
R/L 807. 20. 10. 72 -D			o	o	2.0							
R/L 807. 10. 15. 72 -D			o	o	1.0							
R/L 807. 15. 15. 72 -D			o	o	1.5				15			
R/L 807. 20. 15. 72 -D			o	o	2.0							
R/L 807. 10. 20. 72 -D			o	o	1.0							
R/L 807. 15. 20. 72 -D			o	o	1.5				20			
R/L 807. 20. 20. 72 -D			o	o	2.0							
R/L 807. 10. 25. 72 -D			o	o	1.0	3.45	4.25	6.95		2.5	7.2	7.0
R/L 807. 15. 25. 72 -D			o	o	1.5				25			
R/L 807. 20. 25. 72 -D			o	o	2.0							
R/L 807. 10. 30. 72 -D			o	o	1.0							
R/L 807. 15. 30. 72 -D			o	o	1.5				30			
R/L 807. 20. 30. 72 -D			o	o	2.0							
R/L 807. 10. 35. 72 -D			o	o	1.0							
R/L 807. 15. 35. 72 -D			o	o	1.5				35			
R/L 807. 20. 35. 72 -D			o	o	2.0							
R/L 807. 10. 40. 72 -D			o	o	1.0							
R/L 807. 15. 40. 72 -D			o	o	1.5				40			

Ausführung R oder L angeben / state R or L version
 R = rechts, wie gezeichnet R = RH version shown
 L = links, spiegelbildlich L = LH version, mirror image

Ausdrehen und Fasen Dmin 5.2 mm

Boring and Chamfering Dmin 5.2 mm

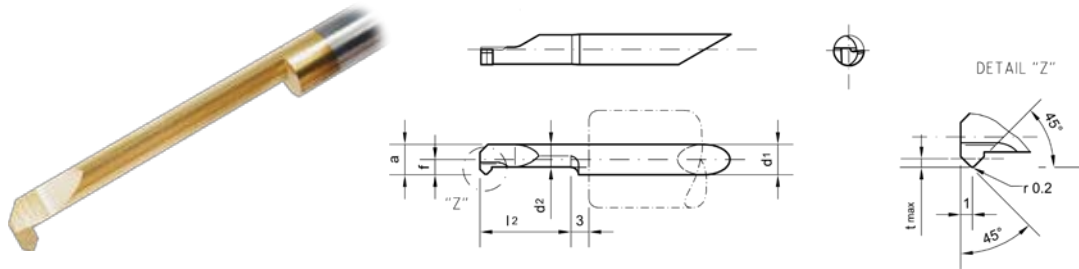

Bezeichnung Part Number	Lager Stock				Maße [mm] Dimensions						
	GK 1120		GK 5120		f	d ₂	a	l ₂	t _{max}	D _{min}	d ₁
	R	L	R	L							
R/L 805. 90. 15. 52 - D			○	○	2.45	3.75	4.95	15		5.2	5.0
R/L 805. 90. 20. 52 - D			○	○				20			
R/L 806. 90. 20. 62 - D			○	○	2.95	3.95	5.95	20	0.7	6.2	6.0
R/L 806. 90. 25. 62 - D			○	○				25			
R/L 807. 90. 20. 72 - D			○	○	3.45	4.25	6.95	20		7.2	7.0
R/L 807. 90. 40. 72 - D			○	○				40			

Ausführung R oder L angeben / state R or L version

Vorstechen und Fasen Dmin 5.2 mm

Pregrooving and Chamfering Dmin 5.2 mm

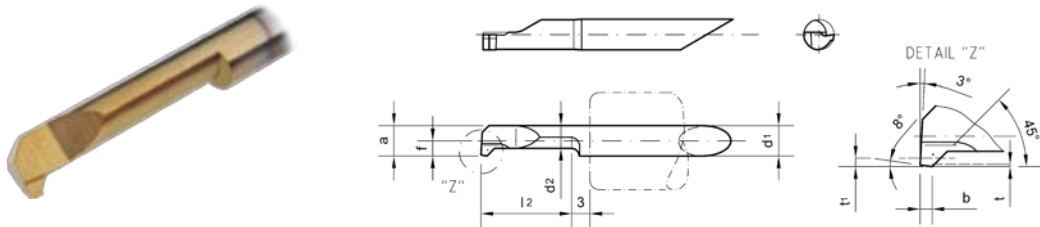

Bezeichnung Part Number	Lager Stock				Maße [mm] Dimensions								
	GK 1120		GK 5120		f	d ₂	a	l ₂	b	t	t ₁	D _{min}	d ₁
	R	L	R	L									
R/L 805. 02. 15. 52 - D			○	○				15				5.2	5.0
R/L 805. 02. 20. 52 - D			○	○	2.45	3.75	4.95	20	1.0	0.2	0.7		
R/L 805. 02. 25. 52 - D			○	○				25					
R/L 805. 02. 30. 52 - D			○	○				30					

Ausführung R oder L angeben / state R or L version

R = rechts, wie gezeichnet
 R = RH version shown
 L = links, spiegelbildlich
 L = LH version, mirror image

Stechen von Vollradiusnuten Dmin 4.2 mm

Full Radius Grooving Dmin 4.2 mm

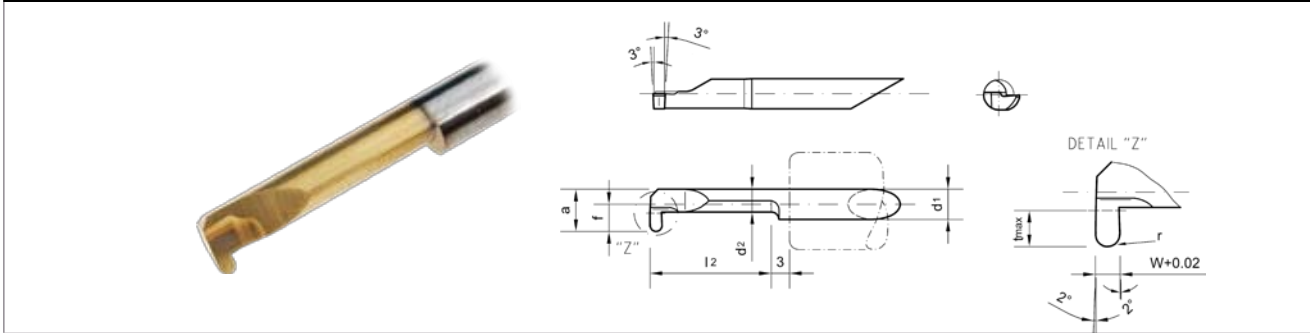

Bezeichnung Part Number	Lager Stock				Maße [mm] Dimensions								
	GK 1120		GK 5120		r	w	f	d ₂	a	l ₂	t _{max}	D _{min}	d ₁
	R	L	R	L									
R/L 804. 09. 15. 42 -D			o	o	0.50	1.0	1.95	2.95	3.95	15	0.8	4.2	4.0
R/L 805. 09. 20. 52 -D			o	o	0.50	1.0							
R/L 805. 14. 20. 52 -D			o	o	0.75	1.5	2.45	3.75	4.95	20	1.0	5.2	5.0
R/L 805. 19. 20. 52 -D			o	o	1.00	2.0							
R/L 806. 09. 25. 62 -D			o	o	0.50	1.0							
R/L 806. 14. 25. 62 -D			o	o	0.75	1.5	2.95	3.95	5.95	25	1.8	6.2	6.0
R/L 806. 19. 25. 62 -D			o	o	1.00	2.0							
R/L 807. 09. 30. 72 -D			o	o	0.50	1.0							
R/L 807. 14. 30. 72 -D			o	o	0.75	1.5	3.45	4.25	6.95	30	2.5	7.2	7.0
R/L 807. 19. 30. 72 -D			o	o	1.00	2.0							

Ausführung R oder L angeben / state R or L version

Ausdrehen 90° Dmin 3.2 mm

Boring 90° Dmin 3.2 mm

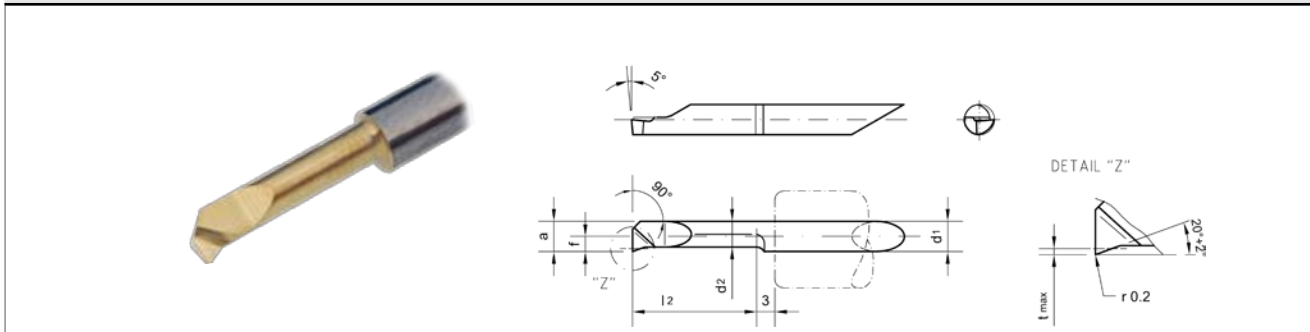

Bezeichnung Part Number	Lager Stock				Maße [mm] Dimensions						
	GK 1120		GK 5120		f	d ₂	a	l ₂	t _{max}	D _{min}	d ₁
	R	L	R	L							
R/L 804. 70. 12. 32 -D			o	o	1.45	2.55	2.95	12	0.2	3.2	
R/L 804. 70. 15. 42 -D			o	o	1.95	3.45	3.95	15	0.3	4.2	4.0
R/L 805. 70. 10. 52 -D			o	o				10			
R/L 805. 70. 15. 52 -D			o	o	2.45	4.25	4.95	15	0.5	5.2	5.0
R/L 805. 70. 20. 52 -D			o	o				20			

Ausführung R oder L angeben / state R or L version

R = rechts, wie gezeichnet
R = RH version shown
L = links, spiegelbildlich
L = LH version, mirror image

Gewindedrehen, Metrisch 60°, Dmin 4.2 mm
Threading, Metric 60°, Dmin 4.2 mm

Teilprofil / Partial Profile

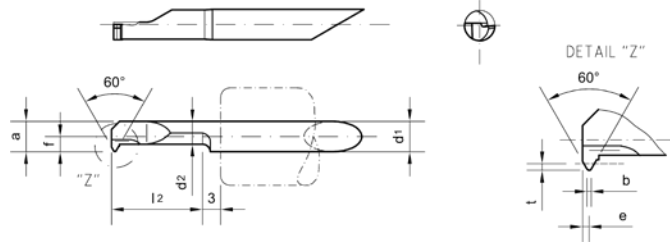

Bezeichnung Part Number	Lager Stock		Maße [mm] Dimensions											
	GK 1120		P	t	b	e	f	a	d ₂	l ₂	D _{min}	d ₁		
	R	L	R	L	R	L	R	L	R	L	R	L		
Regelgewinde / Standard Thread														
R/L 804. 60. 08. 42 - D			○	○	0.80	0.43	0.10	0.45	1.85	3.75	2.70	15	4.0	4.0
R/L 805. 60. 10. 52 - D			○	○	1.00	0.55	0.12	0.55	2.25	4.55	3.55	15	4.8	5.0
R/L 806. 60. 12. 62 - D			○	○	1.25	0.68	0.15	0.65						
R/L 806. 60. 15. 62 - D			○	○	1.50	0.81	0.18	0.75	2.95	5.95	3.95	15	6.2	6.0
Feingewinde / Fine Thread														
R/L 804. 60. 05. 42 - D			○	○	0.50	0.27	0.06	0.35	1.95	3.95	2.95	15	4.2	4.0
R/L 805. 60. 05. 52 - D			○	○	0.50	0.27	0.06	0.35	2.45	4.95	3.75	15	5.2	5.0
R/L 805. 60. 07. 52 - D			○	○	0.75	0.40	0.09	0.45						
R/L 806. 60. 10. 62 - D			○	○	1.00	0.55	0.12	0.55	2.95	5.95	3.95	15	6.2	6.0

Ausführung R oder L angeben / state R or L version

Gewindedrehen, BSW 55°, Dmin 5.2 mm
Threading, BSW 55°, Dmin 5.2 mm

Vollprofil / Full Profile

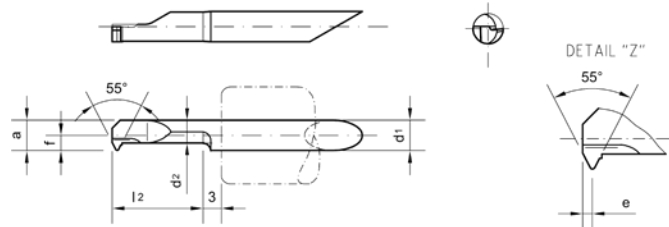

Bezeichnung Part Number	Lager Stock		Maße [mm] Dimensions										
	GK 1120		Gg"/ tpi	e	f	a	d ₂	l ₂	D _{min}	d ₁			
	R	L	R	L	R	L	R	L	R	L			
R/L 805. 55. 28. 52 - D			○	○	28								
R/L 805. 55. 26. 52 - D			○	○	26	0.8	2.45	4.95	3.75	15	5.2	5.0	
R/L 805. 55. 24. 52 - D			○	○	24								
R/L 806. 55. 28. 62 - D			○	○	28								
R/L 806. 55. 26. 62 - D			○	○	26	0.8							
R/L 806. 55. 24. 62 - D			○	○	24								
R/L 806. 55. 22. 62 - D			○	○	22		2.95	5.95	3.95	15	6.2	6.0	
R/L 806. 55. 20. 62 - D			○	○	20	1.0							
R/L 806. 55. 19. 62 - D			○	○	19								

Ausführung R oder L angeben / state R or L version

R = rechts, wie gezeichnet R = RH version shown

L = links, spiegelbildlich L = LH version, mirror image

Gewindedrehen, UN, Dmin 4.2 mm
Threading, UN, Dmin 4.2 mm

Teilprofil / Partial Profile

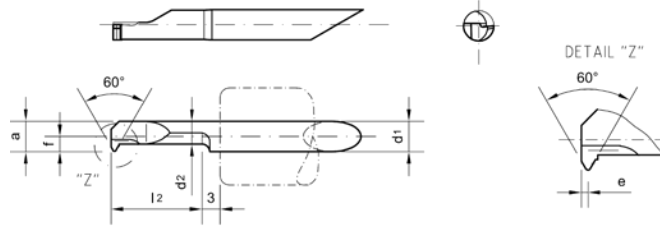
 Drehen
Turning

 Fräswerkzeuge
Milling Tools

 HDS-/VHM-Fräser
HDS-/Solid Carbide
Endmills

 Stech- und
Abstechwerkzeuge
Grooving and
Parting off Tools

 Mini/Micro
Schneidwerkzeuge
Mini/Micro Tools

 Gewinde-
werkzeuge
Threading Tools

 Wendepplattenbohrer
VHM-Bohrer
Indexable Drills
Solid Carbide Drills

Bezeichnung Part Number	Lager Stock				Maße [mm] Dimensions							
	GK 1120		GK 5120		Gg"/ tpi	e	f	a	d ₂	l ₂	D _{min}	d ₁
	R	L	R	L								
R/L 804. 63. 32. 42 -D			○	○	32 - 40	0.45	1.95	3.95	2.95	15	4.2	4.0
R/L 805. 63. 32. 52 -D			○	○	32 - 40	0.45	2.45	4.95	3.75	15	5.2	5.0
R/L 805. 63. 24. 52 -D			○	○	24 - 28	0.55	2.45	4.95	3.75	15	5.2	5.0
R/L 806. 63. 24. 62 -D			○	○	24 - 28	0.55	2.95	5.95	3.95	15	6.2	6.0
R/L 806. 63. 16. 62 -D			○	○	16 - 20	0.70	2.95	5.95	3.95	15	6.2	6.0

Ausführung R oder L angeben / state R or L version

Gewindedrehen, NPT, Dmin 6.2 mm
Threading, NPT, Dmin 6.2 mm

Teilprofil / Partial Profile

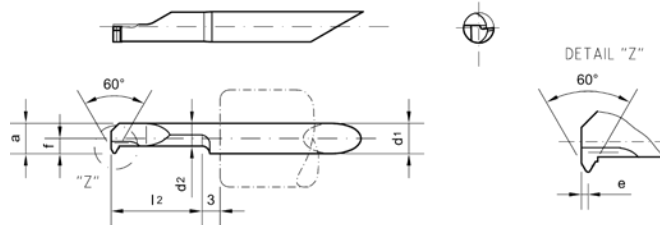

Bezeichnung Part Number	Lager Stock				Maße [mm] Dimensions							
	GK 1120		GK 5120		Gg"/ tpi	e	f	a	d ₂	l ₂	D _{min}	d ₁
	R	L	R	L								
R/L 806. 64. 27. 62 -D			○	○	27	0.8	2.95	5.95	3.95	15	6.2	6.0
R/L 806. 64. 18. 62 -D			○	○	18	1.0	2.95	5.95	3.95	15	6.2	6.0

Ausführung R oder L angeben / state R or L version

R = rechts, wie gezeichnet R = RH version shown

L = links, spiegelbildlich L = LH version, mirror image

Axialstechen in Bohrungen, Dmin 6.2 mm

Face Grooving in Bores, Dmin 6.2 mm

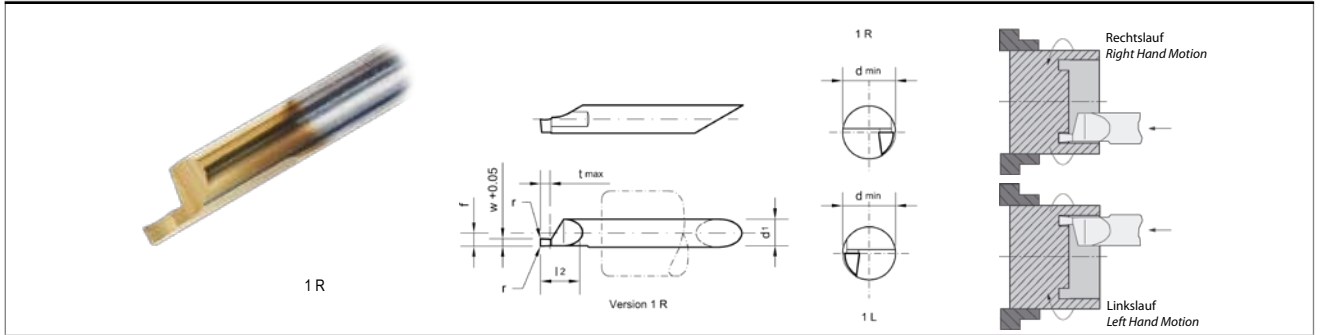

Bezeichnung Part Number	Lager Stock				Maße [mm] Dimensions							
	GK 1120		GK 5120		w _{+0.05}	f	t _{max}	Version	D _{min}	d ₁	l ₂	r
	R	L	R	L								
R 806. 11. 15. 63 - D			○	○	1.0		2.0					
R 806. 12. 15. 63 - D			○	○	1.5		3.0					
R 806. 13. 15. 63 - D			○	○	2.0	2.95	4.0	1 R	6.2	6.0	15	0.15
R 806. 14. 15. 63 - D			○	○	2.5		5.0					
R 806. 15. 15. 63 - D			○	○	3.0		6.0					
L 806. 31. 15. 63 - D			○	○	1.0		2.0					
L 806. 32. 15. 63 - D			○	○	1.5		3.0					
L 806. 33. 15. 63 - D			○	○	2.0	2.95	4.0	1 L	6.2	6.0	15	0.15
L 806. 34. 15. 63 - D			○	○	2.5		5.0					
L 806. 35. 15. 63 - D			○	○	3.0		6.0					

Drehen
Turning

Fräswerkzeuge
Milling Tools

HDS-/VHM-Fräser
HDS-/Solid Carbide
Endmills

Stech- und
Abstechwerkzeuge
Grooving and
Parting off Tools

Mini/Micro
Schneidwerkzeuge
Mini/ Micro Tools

Gewinde-
werkzeuge
Threading Tools

Wendepplattenbohrer
VHM-Bohrer
Indexable Drills
Solid Carbide Drills

Axialstechen am Zapfen, Dmin 6.2 mm

Face Grooving on Pivots, Dmin 6.2 mm

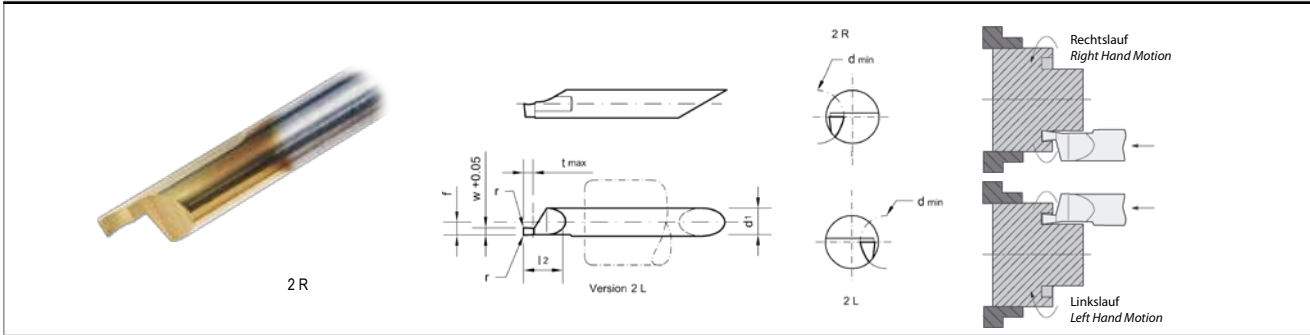

Bezeichnung Part Number	Lager Stock				Maße [mm] Dimensions							
	GK 1120		GK 5120		w _{+0.05}	f	t _{max}	Version	D _{min}	d1	l2	r
	R	L	R	L								
L 806. 21. 15. 63 -D			○	○	1.0		2.0					
L 806. 22. 15. 63 -D			○	○	1.5		3.0					
L 806. 23. 15. 63 -D			○	○	2.0	2.95	4.0	2 R	6.2	6.0	15.2	0.15
L 806. 24. 15. 63 -D			○	○	2.5		5.0					
L 806. 25. 15. 63 -D			○	○	3.0		6.0					
R 806. 41. 15. 63 -D			○	○	1.0		2.0					
R 806. 42. 15. 63 -D			○	○	1.5		3.0					
R 806. 43. 15. 63 -D			○	○	2.0	2.95	4.0	2 L	6.2	6.0	15.2	0.15
R 806. 44. 15. 63 -D			○	○	2.5		5.0					
R 806. 45. 15. 63 -D			○	○	3.0		6.0					

Drehen
Turning

Fräswerkzeuge
Milling Tools

HDS-/VHM-Fräser
HDS-/Solid Carbide
Endmills

Stech- und
Abstechwerkzeuge
Grooving and
Parting off Tools

Mini/Micro
Schneidwerkzeuge
Mini/ Micro Tools

Gewinde-
werkzeuge
Threading Tools

Wendepplattenbohrer
VHM-Bohrer
Indexable Drills
Solid Carbide Drills

**Axialstechen in Bohrungen,
Dmin 16/10 mm (R808), Dmin 20/12 mm (R810)**

Face Grooving in Bores

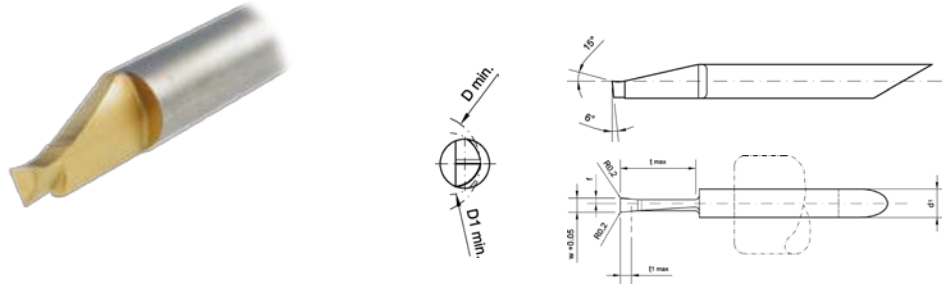

Bezeichnung Part Number	Lager Stock				Maße [mm] Dimensions						
	GK 1120		GK 5120		d ₁	w	f	D _{min}	t _{max}	D _{1 min}	t _{1 max}
	R	L	R	L							
R/L 808. 30. 10. 80 - D			○	○		3.0	0.93		10.0		
R/L 808. 40. 10. 80 - D			○	○	8.0	4.0	1.51	16.0		10.0	3.0
R/L 808. 30. 15. 80 - D			○	○		3.0	0.93		15.0		
R/L 808. 40. 15. 80 - D			○	○		4.0	1.51				
R/L 810. 30. 20. 80 - D			○	○		3.0	0.93				
R/L 810. 40. 20. 80 - D			○	○		4.0	1.35		20.0		
R/L 810. 50. 20. 80 - D			○	○		5.0	1.90				
R/L 810. 30. 25. 80 - D			○	○		3.0	0.93				
R/L 810. 40. 25. 80 - D			○	○	10.0	4.0	1.35	20.0	25.0	12.0	5.0
R/L 810. 50. 25. 80 - D			○	○		5.0	1.90				
R/L 810. 30. 30. 80 - D			○	○		3.0	0.93				
R/L 810. 40. 30. 80 - D			○	○		4.0	1.35		30.0		
R/L 810. 50. 30. 80 - D			○	○		5.0	1.90				

Ausführung R oder L angeben / state R or L version

Drehen
Turning

Fräswerkzeuge
Milling Tools

HDS-/VHM-Fräser
HDS-/Solid Carbide
Endmills

Stech- und
Abstechwerkzeuge
Grooving and
Parting off Tools

Mini/Micro
Schneidwerkzeuge
Mini/ Micro Tools

Gewinde-
werkzeuge
Threading Tools

Wendepplattenbohrer
VHM-Bohrer
Indexable Drills
Solid Carbide Drills

Schnittgeschwindigkeits-Empfehlungen für Micro-Schneidwerkzeuge

Cutting Speed-Recommendations for Micro Cutting Tools

	Werkstückwerkstoff <i>Material</i>	Legierung <i>Alloy</i>	Schnittgeschwindigkeiten v_c [m/min] <i>Cutting Speeds v_c [m/min]</i>	
			GK 1120 (K20F)	GK 5120 (K20F-TiN)
A (P)	Unlegierter Stahl <i>Mild steel</i>	geglüht / <i>annealed</i> < 0,15% C	-	110 - 300
		geglüht / <i>annealed</i> 0,15% - 0,45% C	30 - 110	80 - 300
		vergütet / <i>heat treated</i> > 0,45% C	-	90 - 230
	Legierter Stahl <i>Alloy steel</i>	niedrig / <i>low</i>	-	70 - 270
		mittel / <i>medium</i>	30 - 80	70 - 220
		hoch / <i>high</i>	-	60 - 150
R (M)	Rostfreier Stahl <i>Stainless steel</i>	austenitisch / <i>austenitic</i>	40 - 80	70 - 160
		martensitisch / <i>martensitic</i>	40 - 80	70 - 160
F (K)	Stahlguss <i>Cast iron</i>	unlegiert / <i>unalloyed</i>	-	80 - 220
		legiert / <i>alloyed</i>	-	40 - 150
	Grauguss <i>Grey cast iron</i>		70 - 90	40 - 170
N	Aluminium		200 - 250	330 - 1070
		~ 50 HB	700 - 850	100 - 1200
		~ 100 HB	280 - 350	190 - 860
	Bronze, Messing, Rotguss <i>Bronze, brass, red brass</i>		90 - 180	-
S	Nickel-Basis <i>Nickel base</i>		20 - 60	-

Vorschub Einstechen <i>Feed Turning</i>	0,01 - 0,02 mm / U mm / rev.
Vorschub Ausdrehen <i>Feed Turning</i>	0,01 - 0,05 mm / U mm / rev.

Die Verwendung von Kühlschmiermitteln wird empfohlen.

Drehen
Turning

Fräswerkzeuge
Milling Tools

HDS-/VHM-Fräser
HDS-/ Solid Carbide
Endmills

Stech- und
Abstechwerkzeuge
Grooving and
Parting off Tools

Mini/Micro
Schneidwerkzeuge
Mini/ Micro Tools

Gewinde-
werkzeuge
Threading Tools

Wendeplattenbohrer
VHM-Bohrer
Indexable Drills
Solid Carbide Drills